

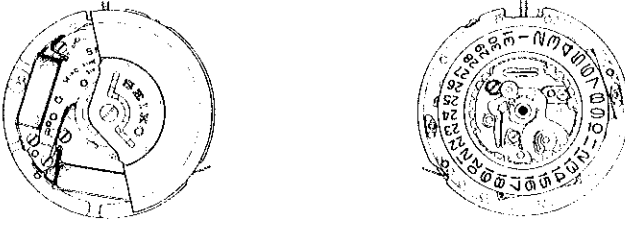

PARTS CATALOGUE / TECHNICAL GUIDE

Cal. 5M22A

Cal. 5M23A

[SPECIFICATIONS]

		Cal. No.	5M22A	5M23A
Item				
Movement				
			The illustrations refer to Cal. 5M22A. (x 1.0)	
Movement size	Outside diameter		ø27.6 mm	
	Casing diameter		ø27.0 mm	
	Height		4.2 mm	4.3 mm
Time indication			3 hands	
Driving system			Step motor (Load compensated driving pulse type)	
Additional mechanism			<ul style="list-style-type: none"> • Automatic generating system • Power reserve indicator • Overcharge prevention function • Electronic circuit reset switch • Train wheel setting device • Date calendar • Day calendar (for Cal. 5M23 only) • Instant setting device for date calendar • Instant setting device for day calendar (for Cal. 5M23A only) 	
Loss/gain			Monthly rate at normal temperature range: less than 15 seconds	
Regulation system			Nil	
Measuring gate by quartz tester			Use 10-second gate.	
Power supply	Power generator		Automatic generating system	
	Capacitor		Matsushita EECW2R4E334	
Operating voltage range			Capacitor voltage: 0.5 ~ 2.3V	
Expected life per charge			From full charge to stoppage: Approx. 72 hours	
Jewels			6 jewels	

SEIKO CORPORATION

PARTS CATALOGUE

Cal. 5M22A, 5M23A

Disassembling procedures Figs. : (1) → (51)

Reassembling procedures Figs. : (51) → (1)

Lubricating: Types of oil

● Moebius A

⊖ SEIKO Watch Oil S-6

Oil quantity

○ Normal quantity

◁ Extremely small

Ex.: Cal. 5M23A

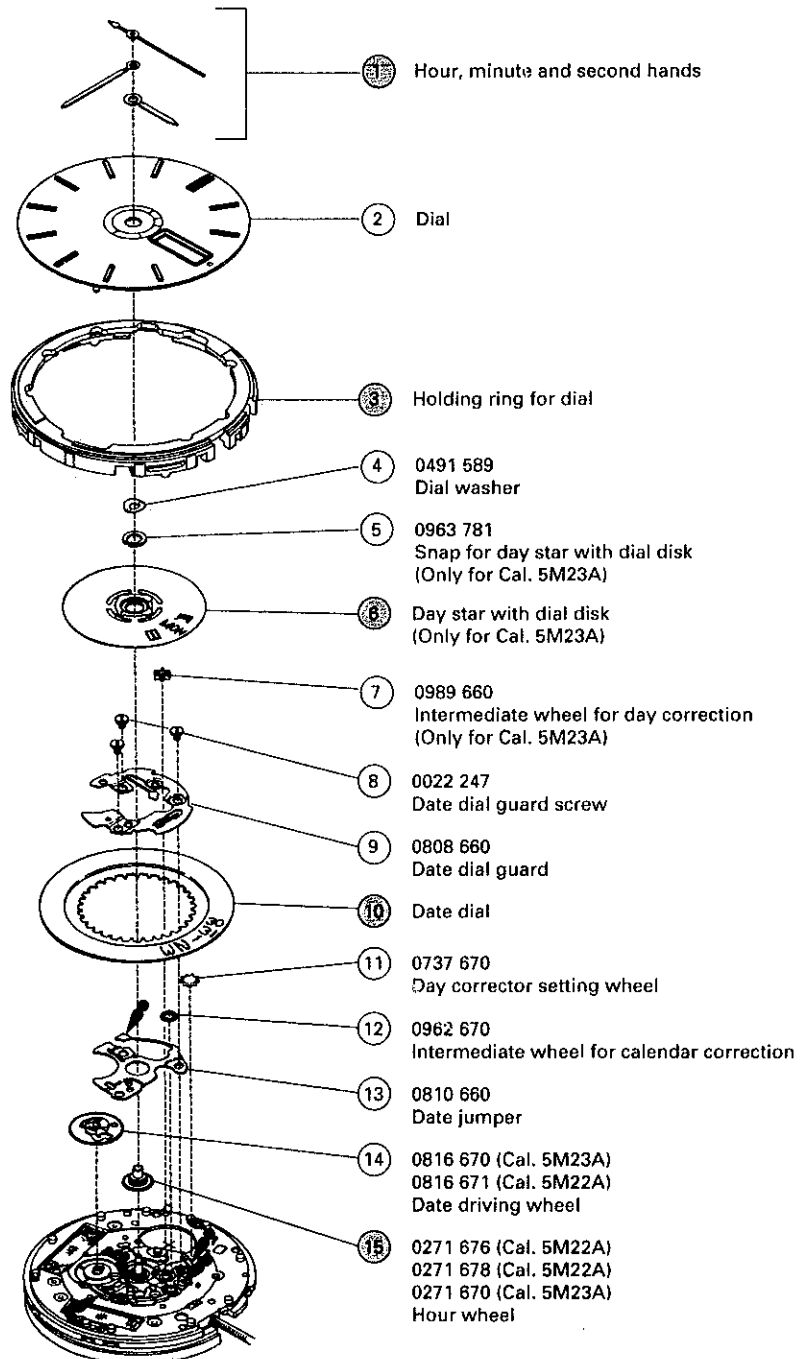



⊖ → Please see the remarks on the following pages.

PARTS CATALOGUE

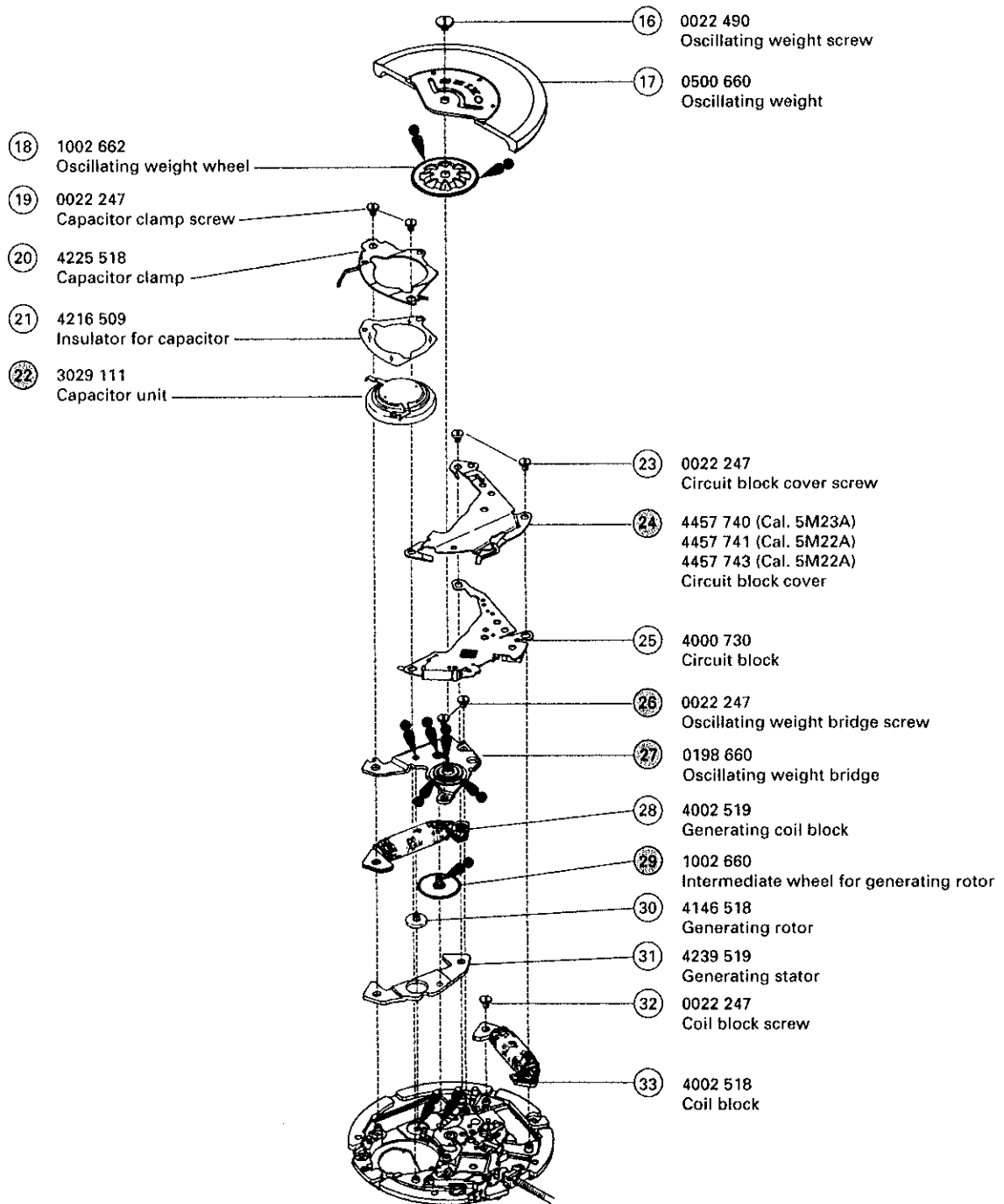
Cal. 5M22A, 5M23A



  Please see the remarks on the following pages.

PARTS CATALOGUE

Cal. 5M22A, 5M23A

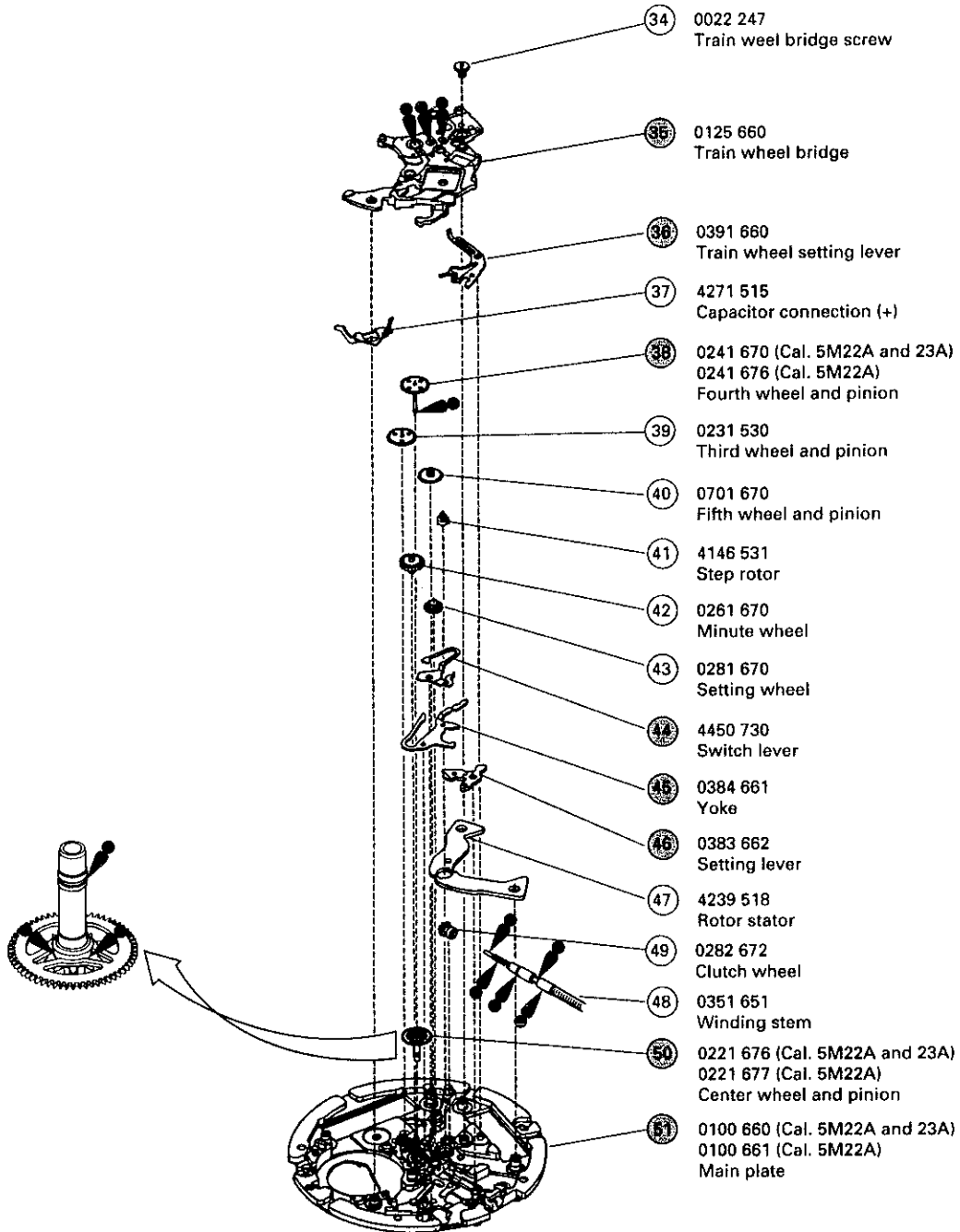

  Please see the remarks on the following pages.

PARTS CATALOGUE

Cal. 5M22A, 5M23A

Remarks:

③ Holding ring for dial

The type of holding ring for dial is determined based on the design of cases. Check the case number and refer to "SEIKO Casing Parts Catalogue" to choose a corresponding holding ring for dial.

⑥ Day star with dial disk (Only for Cal. 5M23A)

Part code	Language	Color of figure	Color of background
0150 659	English ↔ Spanish	White	Black

The type of day star with dial disk is determined based on the design of cases. If any other type of day star with dial disk is required, please specify the number inscribed on the disk.

⑩ Date dial

Cal. No.	Part code	Position of crown	Color of figure	Color of background
5M22A	0801 954	3 o'clock	Black	White
5M23A	0878 672	3 o'clock	White	Black

The type of date dial is determined based on the design of cases. Check the case number and refer to "SEIKO Casing Parts Catalogue" to choose a corresponding date dial.

⑮ Hour wheel (Cal. 5M22A)

⑳ Circuit block cover (Cal. 5M22A)

㉓ Fourth wheel and pinion (Cal. 5M22A)

㉕ Center wheel and pinion (Cal. 5M22A)

㉙ Main plate (Cal. 5M22A)



Combination:

* The hand installation heights can be discerned from the shape of the following parts. Refer to the table on the next page.

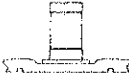
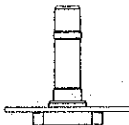
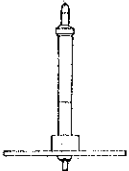

PARTS CATALOGUE

Cal. 5M22A, 5M23A

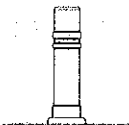
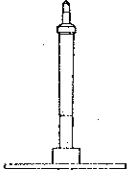
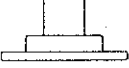
[Cal. 5M22A]

Discrimination		Main plate	Center wheel and pinion	Fourth wheel and pinion	Hour wheel	Circuit block cover
Height	Numeral for discrimination					
Standard type	2	 0100 661	 0221 677	 0241 676	 0271 676	"2" is printed to indicate the hand installation height. 4457 741
Long type	3	 0100 660	 0221 676	 0241 670	 0271 678	"3" is printed to indicate the hand installation height. 4457 743

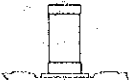
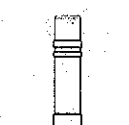
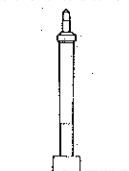
[Cal. 5M23A]

Discrimination		Main plate	Center wheel and pinion	Fourth wheel and pinion	Hour wheel	Circuit block cover
Height	Numeral for discrimination					
Standard type	2	 0100 660	 0221 676	 0241 670	 0271 670	"2" is printed to indicate the hand installation height. 4457 740

TECHNICAL GUIDE

Cal. 5M22A, 5M23A

- The explanation here is only for the particular points of Cal. 5M22A and 5M23A.
- For the repairing, checking and measuring procedures, refer to the "TECHNICAL GUIDE, GENERAL INSTRUCTIONS".

I. STRUCTURE OF THE CIRCUIT BLOCK

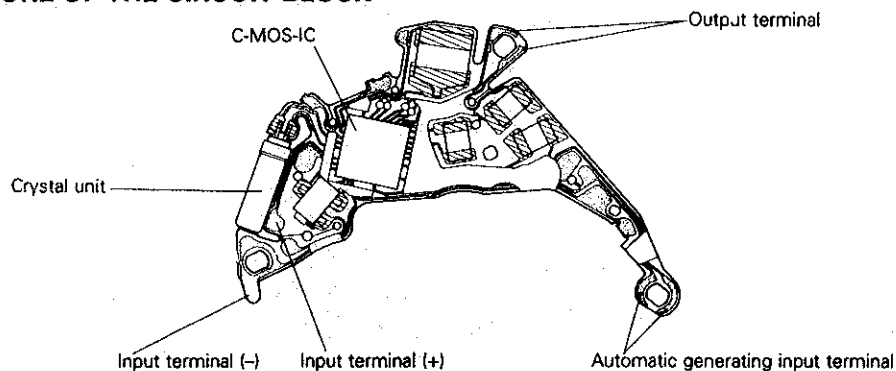

II. REMARKS ON DISASSEMBLING AND REASSEMBLING

① Hands

• How to install

Place the movement directly on the riveting plate shown in the illustration with the oscillating weight side down, so that the oscillating weight screw will not be damaged. Then, press in the hands.

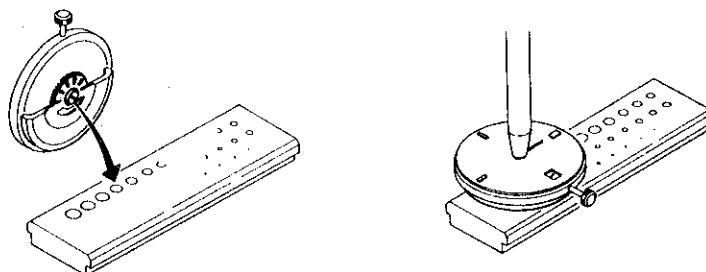

② Capacitor unit

- Be sure to observe the correct polarity of the capacitor unit. The lead terminal is installed on the (-) side as shown in the illustration.
- To install the capacitor unit, set the "A" portion to the hole of the main plate, and then push the "B" portion.

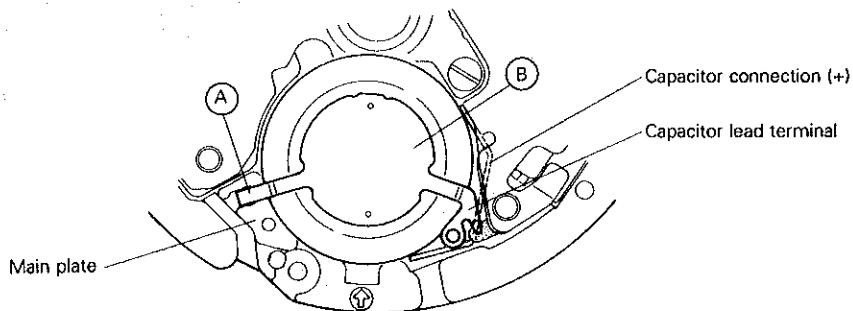

⑥ Oscillating weight bridge screw

⑦ Oscillating weight bridge

- Before tightening the oscillating weight bridge screw, check that the upper pivot of the generating rotor is inserted properly.
- Be sure to lubricate the upper and lower pivots of the generating rotor and intermediate wheel for generating rotor in the quantity specified in the illustration.
- Be sure to lubricate the ball-bearing of the oscillating weight bridge as shown in the illustration.

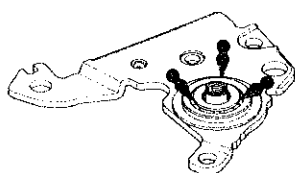
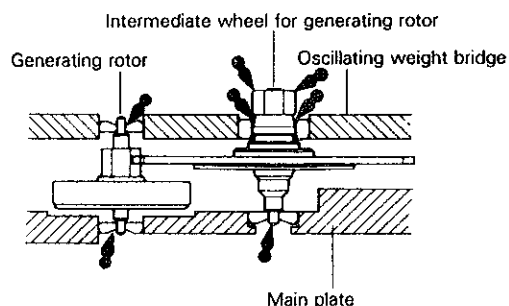

29 Intermediate wheel for generating rotor

• Lubricating

Refer to the illustration at right.

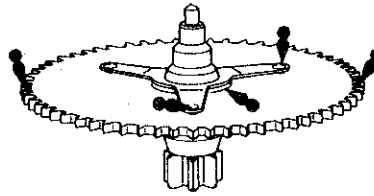

35 Train wheel bridge

• Setting position

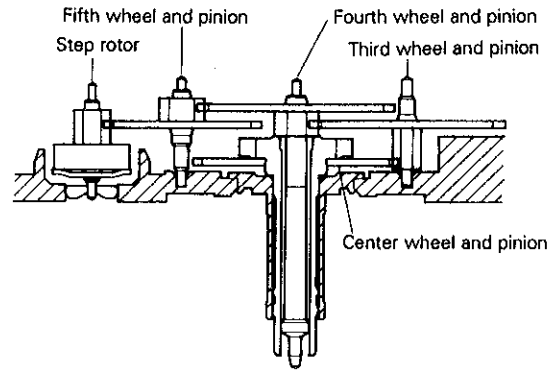
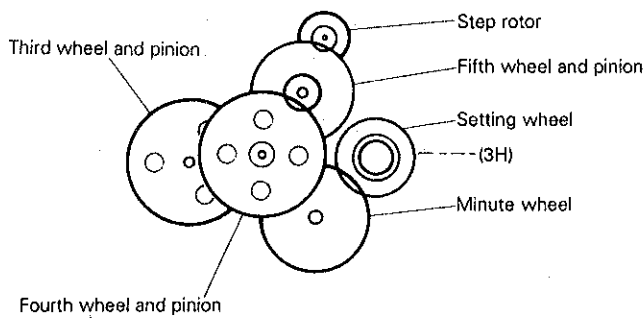

36 Train wheel setting lever

44 Switch lever

45 Yoke

46 Setting lever

• Setting position and lubricating

Refer to the illustration at right.

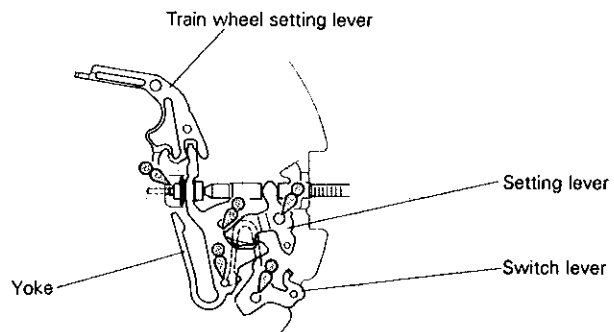

50 Center wheel and pinion

• Lubricating

Refer to the illustration at right.

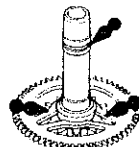

III. VALUE CHECKING AND ADJUSTMENT

- **Coil block resistance**

2.9K Ω ~ 3.4K Ω

- **Generating coil block resistance**

280 Ω ~ 380 Ω

- **Current consumption**

For the whole of the movement : 1.0 μ A

For the circuit block alone : 0.5 μ A

- **Measuring the current consumption for the whole of the movement**

- 1) Connect the tester as shown in the illustration.

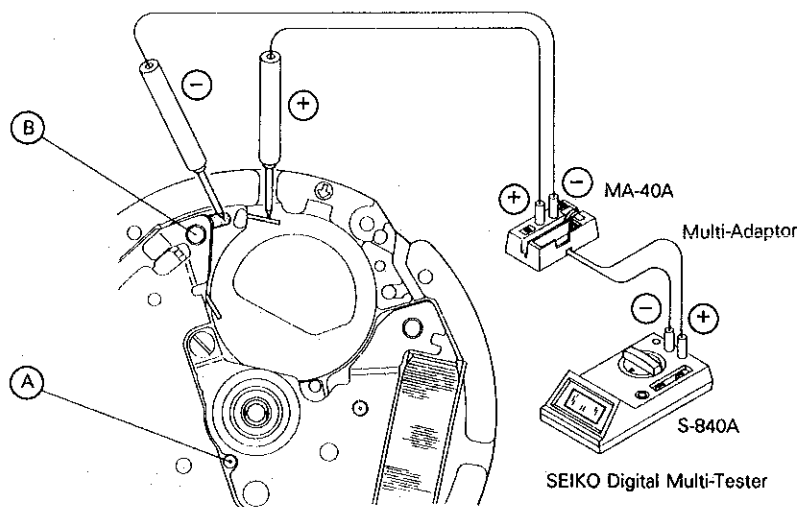

- 2) Start the measurement about 20 seconds after connecting the tester, checking that a stable measurement is obtained.
- 3) When measuring, look through the upper hole jewel for step rotor (A) in the illustration, to check that the step rotor is rotating.
- 4) If a stable measurement is not obtained for the current consumption, temporarily tighten the capacitor clamp screws at the hole (B) and then measure the current consumption again.

- **Measuring the current consumption for the circuit block alone**

Start the measurement about 20 seconds after connecting the tester, checking that a stable measurement is obtained.

Remarks:

When the current consumption exceeds the standard value for the whole of the movement but is less than the standard value for the circuit block alone, overhaul and clean the movement parts and then measure current consumption for the whole of the movement again.

The driving pulse generated to compensate a heavy load that may apply on the gear train, etc. is considered to cause excessive current consumption for the whole of the movement.

• **Checking the automatic generating system**

1) With the watch complete (case back opened), apply the probes of the tester to the capacitor unit as shown in the illustration to measure the initial voltage.

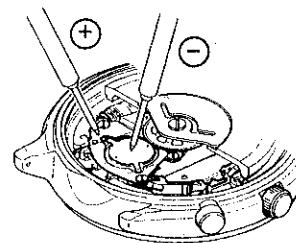

2) Close the case back temporarily, and swing the watch from side to side approximately 100 times rhythmically (at a rate of 1.5 times a second) with a snap of the wrist as shown in the illustration.

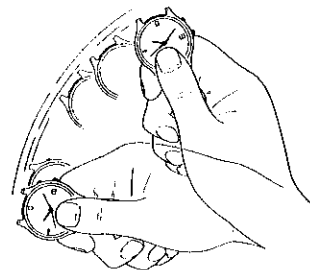

3) Remove the case back, and measure the voltage of the capacitor unit in the same manner as in the step 1) above.

4) If the voltage obtained has increased more than 0.1V from the initial voltage, the automatic generating system is normally operating.

Ex.) Initial voltage: 0.5V → 0.6V: Normal operation

Remarks:

When the watch completely stops, swinging it a few times moves the second hand at two-second intervals, but it stops after a few seconds.

This is not a malfunction, indicating that the watch will normally operate if swung a few more times.

Recharging information: Number of swings required and the duration of charge until the watch stops operating

Cal. 5M Series watches are equipped with a power reserve indicator. The current power reserve can be checked using the second hand at the press of the button at the 2 o'clock position.

Number of swings	Duration of charge	Quick movement of the second hand when the power reserve indicator function is activated
100	Approx. 3 hours	5 seconds
400	Approx. 1 day	10 seconds
600	Approx. 2 days	20 seconds
800	Approx. 3 days	30 seconds

* The table above assumes that the initial voltage of the capacitor unit is 0.5V.

Remarks:

When the capacitor is replaced with a new one, the initial voltage is 0V and, therefore, swing the watch approximately 200 times more than specified in the table.